



US00D974918S

(12) **United States Design Patent** (10) **Patent No.:** **US D974,918 S**
Libby et al. (45) **Date of Patent:** **** Jan. 10, 2023**

(54) **COSMETICS BOTTLE**

OTHER PUBLICATIONS

(71) Applicant: **Victoria’s Secret Stores Brand Management, LLC**, Reynoldsburg, OH (US)

Men’s Fine Fragrance—Victoria’s Secret. Date first available: Mar. 21, 2022. Site visited: Aug. 29, 2022. Available online: <https://www.victoriasecret.com/us/beauty/fragrances/for-him> (Year: 2022).*

(Continued)

(72) Inventors: **Jessica Libby**, New York, NY (US); **Stephen Moss**, Brooklyn, NY (US); **Sandra Monteparo**, Brooklyn, NY (US); **Jeffrey Uhl**, Westhampton Beach, NY (US)

Primary Examiner — Catherine S Posthauer
Assistant Examiner — Joan E. Diehl
(74) *Attorney, Agent, or Firm* — Andrus Intellectual Property Law, LLP

(73) Assignee: **Victoria’s Secret Stores Brand Management, LLC**, Reynoldsburg, OH (US)

(57) **CLAIM**
The ornamental design for a cosmetics bottle, as shown and described.

(**) Term: **15 Years**

DESCRIPTION

(21) Appl. No.: **29/770,765**

FIG. 1 is a top perspective view of a first embodiment of a cosmetics bottle according to our new and ornamental design;

(22) Filed: **Feb. 16, 2021**

FIG. 2 is a front elevation view thereof;

(51) **LOC (14) CL.** **09-01**

FIG. 3 is a rear elevation view thereof;

(52) **U.S. Cl.**
USPC **D9/652**

FIG. 4 is a left side elevation view thereof;

(58) **Field of Classification Search**
USPC D9/652, 542, 432, 434–436, 452, 516,
D9/530, 544–545, 559–560, 564, 565,
(Continued)

FIG. 5 is a right side elevation view thereof;

FIG. 6 is a top plan view thereof; and

FIG. 7 is a bottom plan view thereof.

FIG. 8 is a top perspective view of a second embodiment of a cosmetics bottle according to our new and ornamental design;

(56) **References Cited**

FIG. 9 is a front elevation view thereof;

FIG. 10 is a rear elevation view thereof;

FIG. 11 is a left side elevation view thereof;

FIG. 12 is a right side elevation view thereof;

FIG. 13 is a top plan view thereof; and,

FIG. 14 is a bottom plan view thereof.

The dash-dot broken lines represent the boundaries of the claimed design and form no part of the claim. The evenly dashed broken lines outside the boundary lines represent portions of the cosmetics bottle that form no part of the claimed design.

U.S. PATENT DOCUMENTS

D114,008 S * 3/1939 Blunt D9/652
D134,266 S * 11/1942 Taylor D9/652
(Continued)

FOREIGN PATENT DOCUMENTS

GB 8202986000-1000 * 3/2019
JP D1670318 * 10/2020
WO WO-D203160-001 * 8/2020

1 Claim, 12 Drawing Sheets

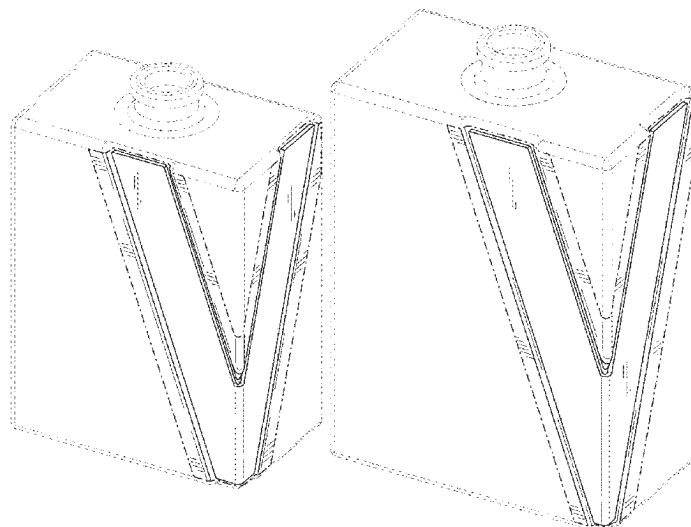

(58) **Field of Classification Search**

USPC D9/570, 575, 715, 719; D28/4-7, 76-79,
 D28/82-83, 91.1; D3/202, 203.2, 901;
 D14/485-493; 215/382-383; D11/157,
 D11/200, 229, 116, 131, 86
 CPC . A61K 9/48; A61K 8/02; B65D 35/10; B65D
 35/24; B65D 35/28; B65D 35/02; B65D
 35/04; B65D 35/08; B65D 35/36; B65D
 35/38; B65D 5/0227; B65D 5/001; B65D
 5/0254; B65D 5/0045; B65D 5/18; B65D
 5/2033; B65D 5/38; B65D 47/2018
 See application file for complete search history.

D469,357 S *	1/2003	Verherbrugghen	D9/554
D507,174 S *	7/2005	Katz	D9/738
D536,259 S *	2/2007	Herrmann	D9/573
D589,814 S *	4/2009	Holzner	D9/563
D614,040 S *	4/2010	Holmes	D9/542
D656,838 S *	4/2012	Mouquet	D9/652
D664,039 S *	7/2012	Monteparo	D9/600
D705,663 S *	5/2014	Guichot	D9/546
D711,426 S *	8/2014	Hollobaugh	D14/490
D790,356 S *	6/2017	Mai	D9/652
D924,718 S *	7/2021	Rizzo	D11/81

OTHER PUBLICATIONS

Diesel Bad Eau de Toilette Spray for Men. Date first available: Oct. 18, 2021. Site visited: Sep. 6, 2022. Available online: https://www.amazon.com/Diesel-Bad-Toilette-Spray-Cologne/dp/B09CF27CW5/ref=cm_cr_ar_p_d_product_top?ie=UTF8 (Year: 2021).*

* cited by examiner

(56)

References Cited

U.S. PATENT DOCUMENTS

D259,173 S *	5/1981	Lauren	D9/560
D441,314 S *	5/2001	Nisguretsky	D11/86

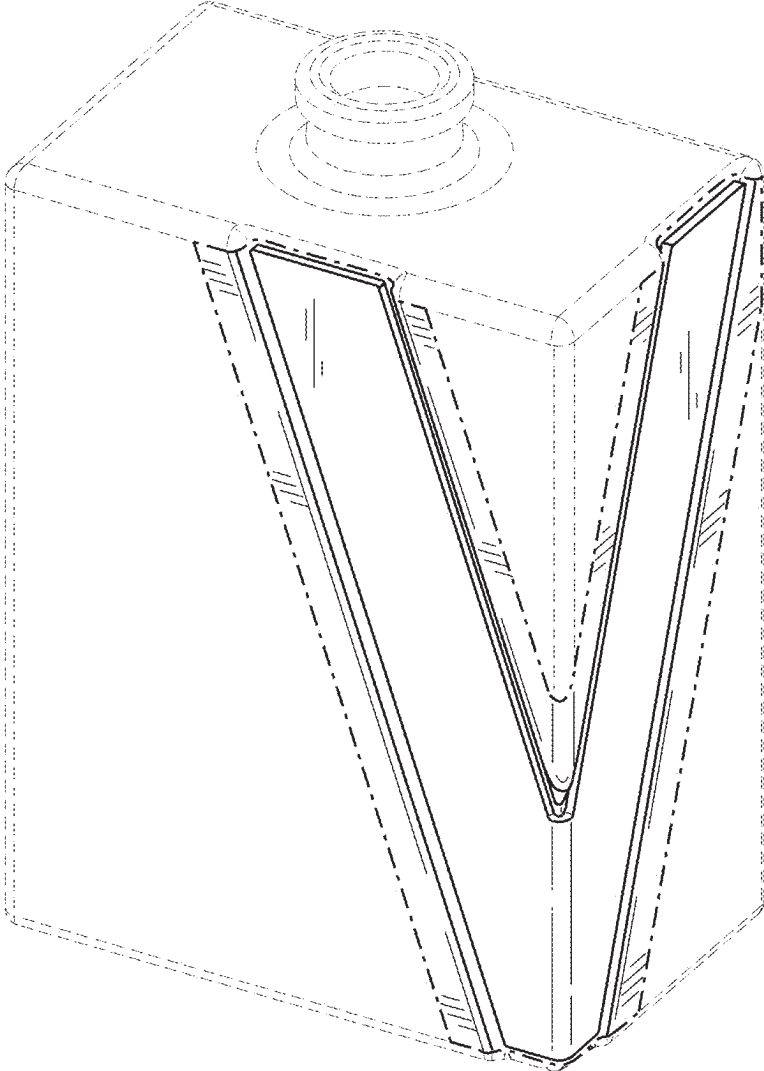

FIG. 1

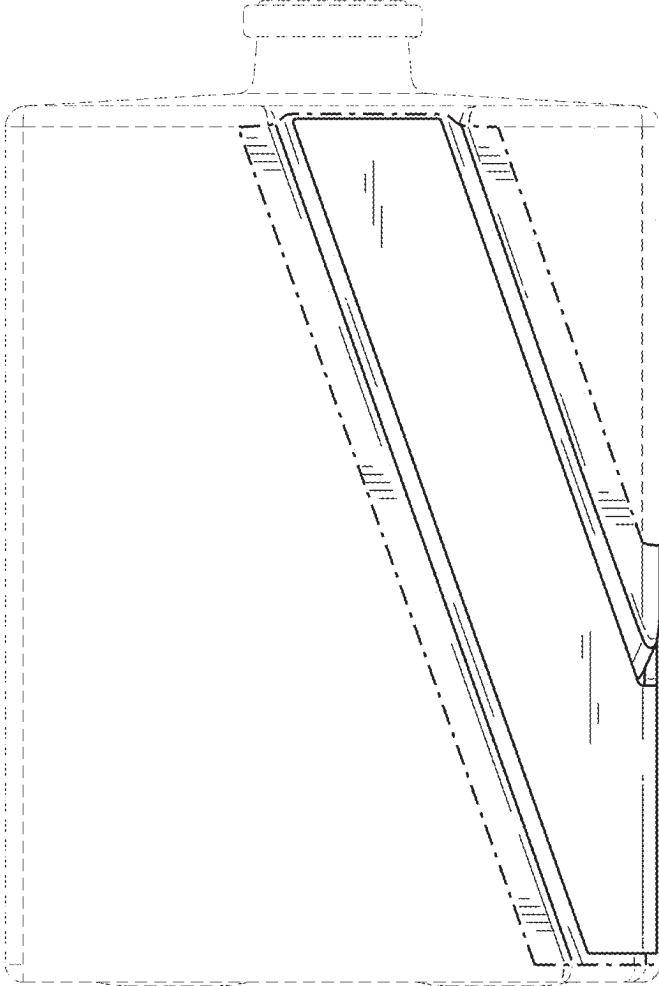

FIG. 2

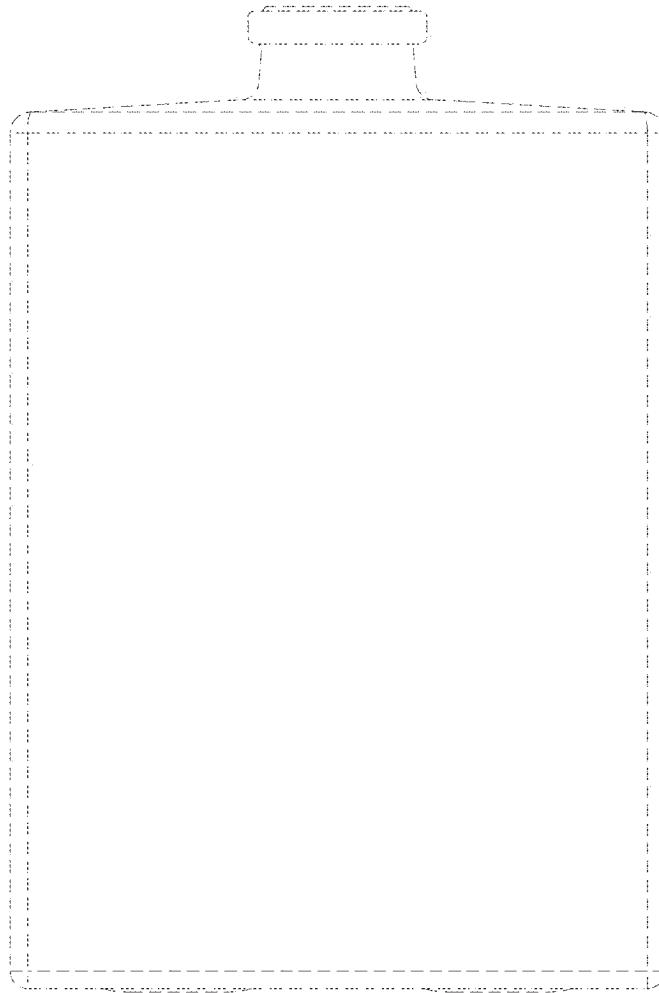

FIG. 3

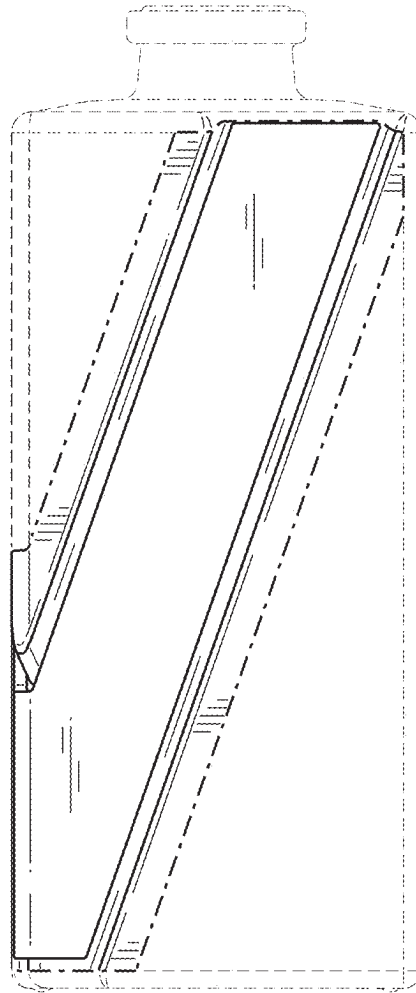

FIG. 4

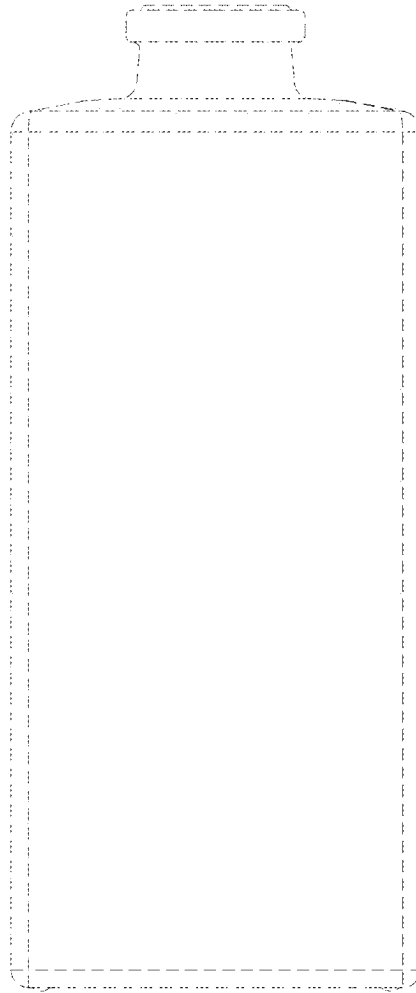

FIG. 5

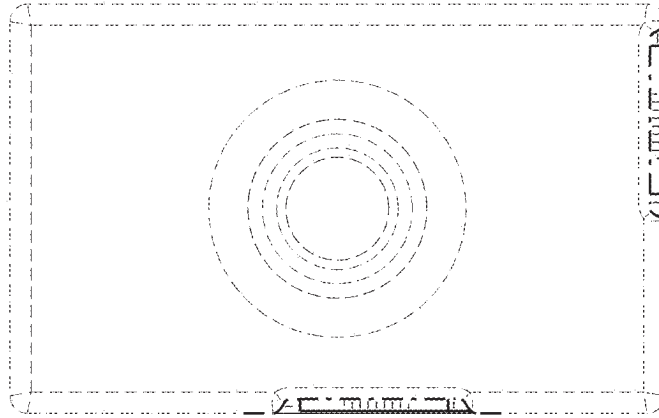

FIG. 6

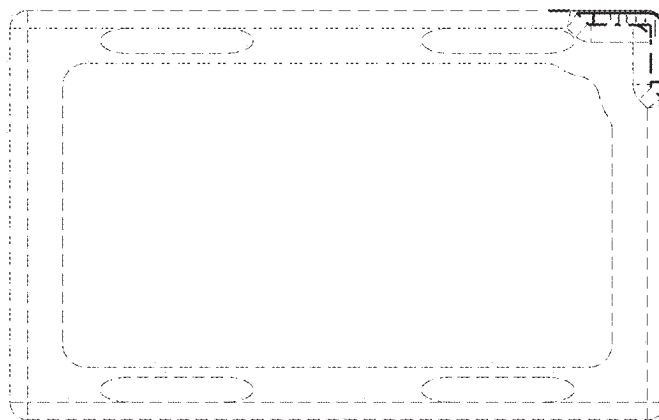

FIG. 7

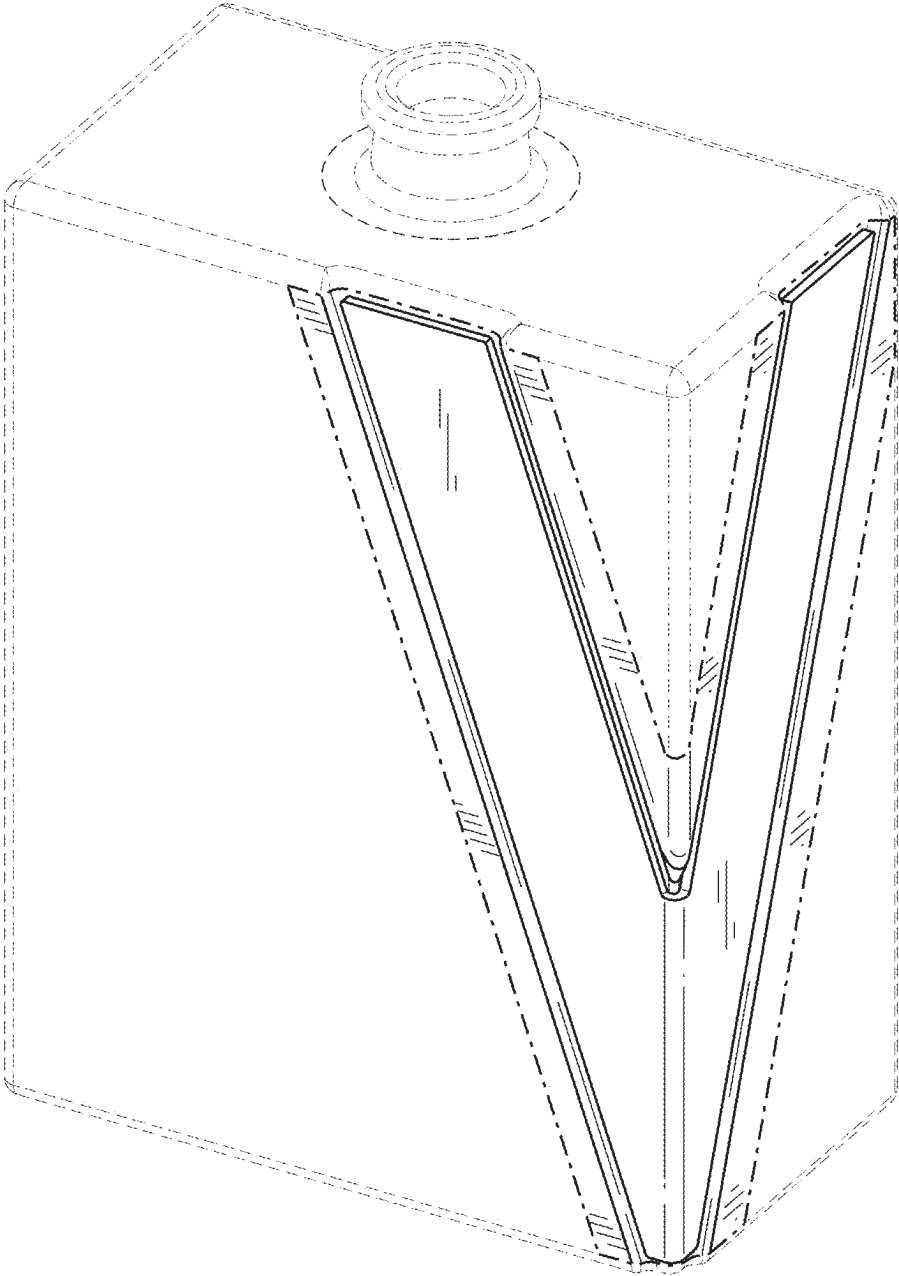

FIG. 8

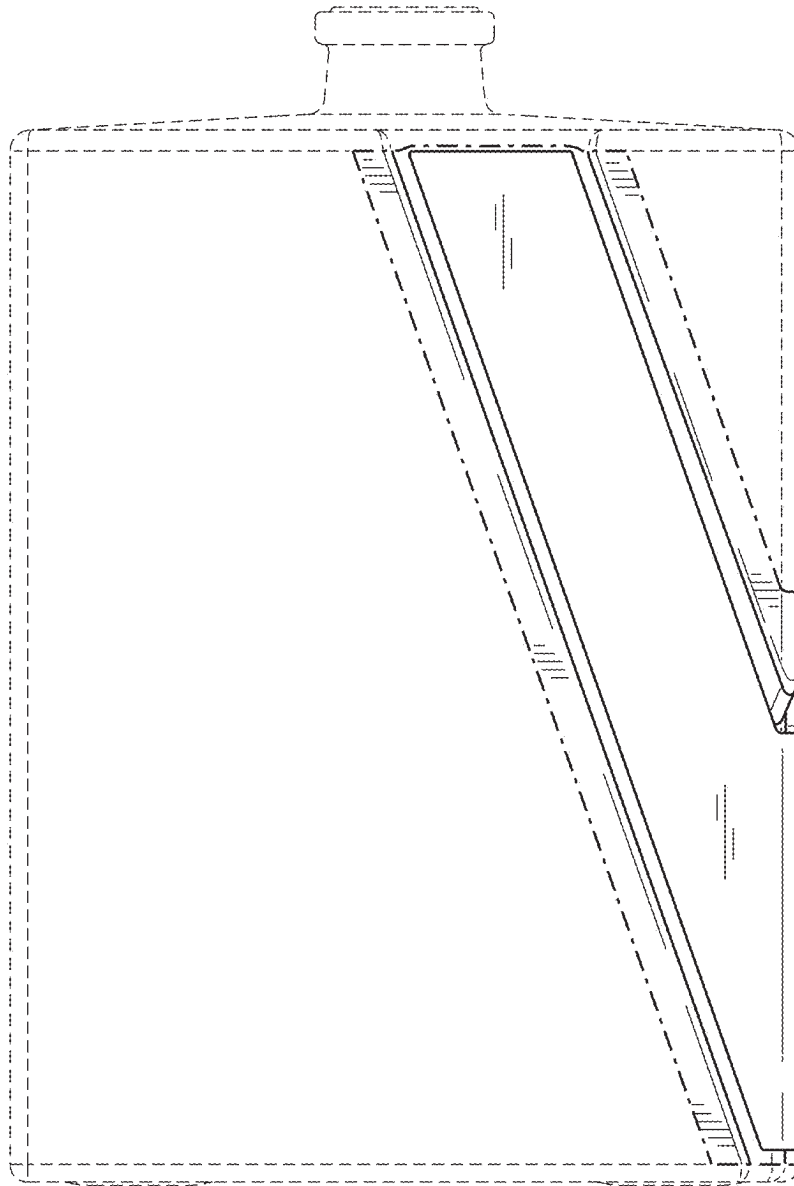

FIG. 9



FIG. 10

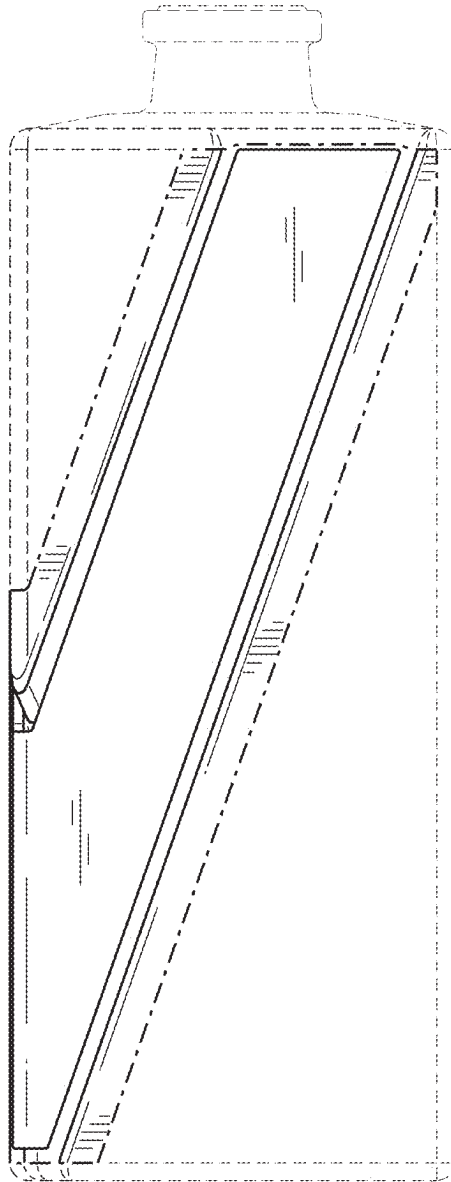

FIG. 11

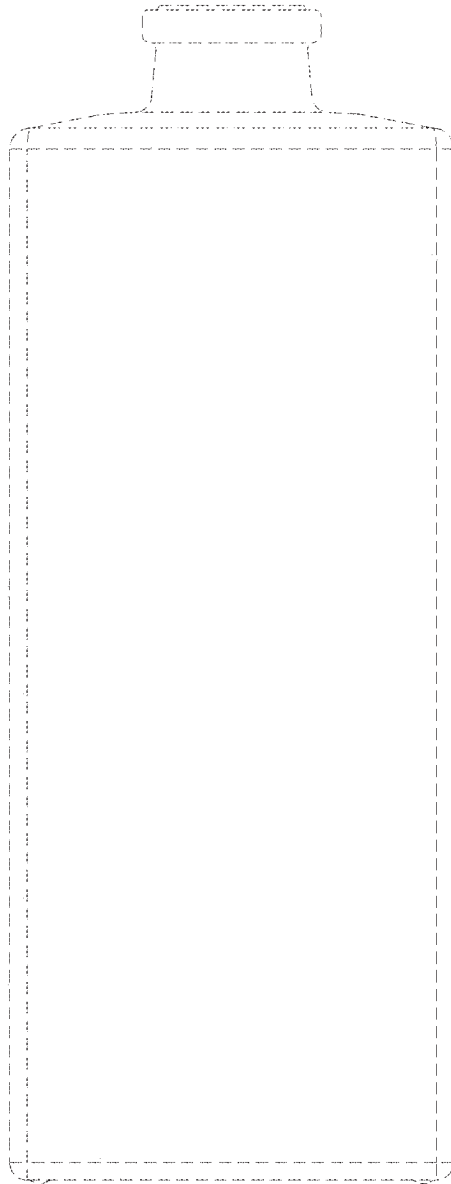

FIG. 12

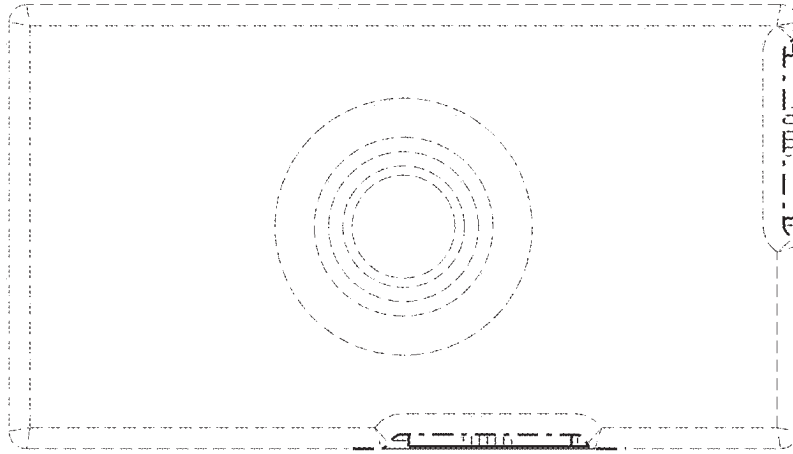

FIG. 13

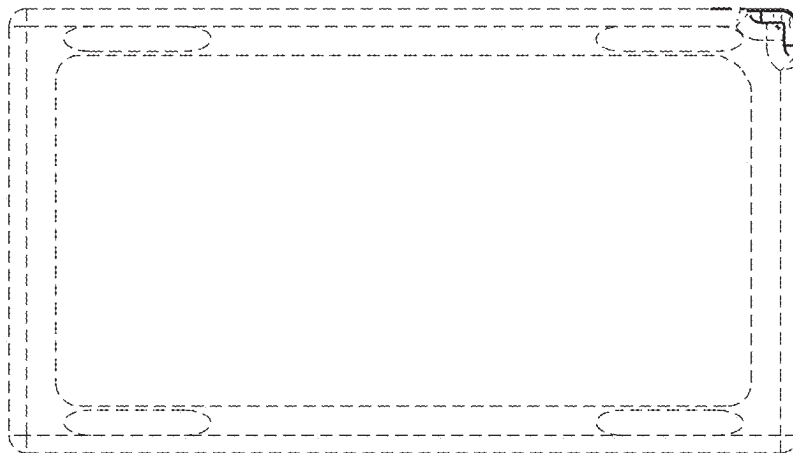

FIG. 14